



Section II – Installation Procedure

Section II – Installation Procedure

A. Installation Precautions

-  1. Use Seat & Floor Protectors to avoid damage to surfaces. (Fig. A1)
-  2. Wear protective latex gloves while cleaning factory panels.

NOTE: The use of protective latex gloves during cleaning is mentioned as a precaution to those installers who may be sensitive to the chemicals being used in this process. The use of protective gloves is not mandatory.

-  3. When cleaning with Alcohol/Water Solution

-  A. Always use a clean (lint free, scratch resistant) soft cloth (or wipe), and clean a small area at a time (~3 ft. x 3ft. max). (Fig A2)

-  B. Apply alcohol/water solution to cloth & wipe. Do not spray cleaning solutions directly to any vehicle surfaces. (Fig. A3).

-  C. Clean surface thoroughly and wipe dry immediately with a new clean cloth. Do not allow cleaner to air dry. (Fig. A4).

-  4. Dash Appliqué must be between 70°F and 110°F (just prior to actual installation).

-  5. Vehicle dash surfaces must be between 70°F and 110°F (just prior to actual installation).

- 6. Use pull-tabs to remove 3M liners. (Fig. A5).

-  A. Do not touch or allow debris or contaminants to come into contact with the adhesive backing before installation.

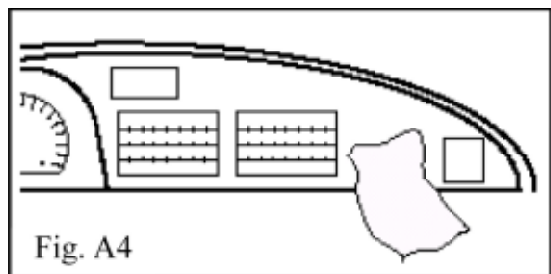
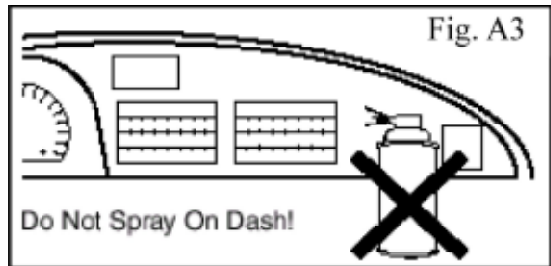
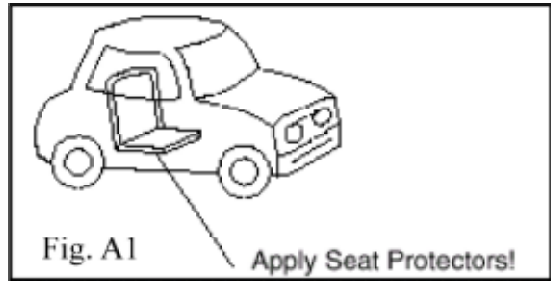

Section II – Installation Procedure

B. Inspection of Parts

1. Inspect parts prior to installation to avoid unnecessary removal. (Fig. D1).



C. Dry Fit Parts

-  1. Check placement for alignment of each part.

D. Clean Factory Surfaces

1. Thoroughly clean (using method in Step A.3) all applicable surfaces highlighted in Fig. D1.

E. Install Rear Deck Trim

-  1. Warm up vehicle surfaces (as required).
- A. Use heat gun, infrared lamps, shop heat or vehicle heating system to heat surfaces to a temperature of at least 70°F. Keep heat gun at lowest setting, 6” from surfaces.
2. Remove adhesive liners from part. Be sure not to touch adhesive backing prior to installation.
3. Position and secure part.
- A. Align cutouts around logo.
 - B. Align part uniformly to edge of factory components. Edge of appliqué should be flush to edge of factory component, ±1.0mm. (Fig. E1).
 - C. Gently touch part into position.
4. Verify alignment.
-  5. Press firmly into place. Roll fingertips in a back and forth motion to set adhesive. Be sure to roll thumb along outside and inside edges while applying pressure.

F. Install Rear Logo Insert Trim (4 pieces)

-  1. Follow steps to warm components as required.
2. Remove adhesive liner from part.

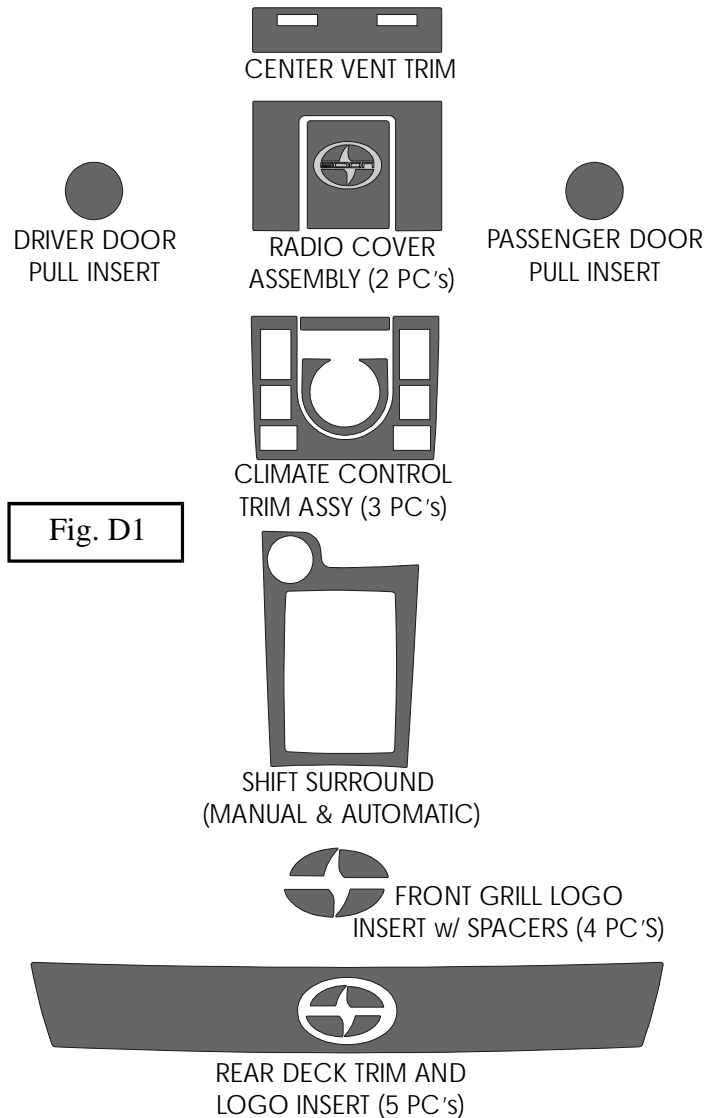

Fig. D1

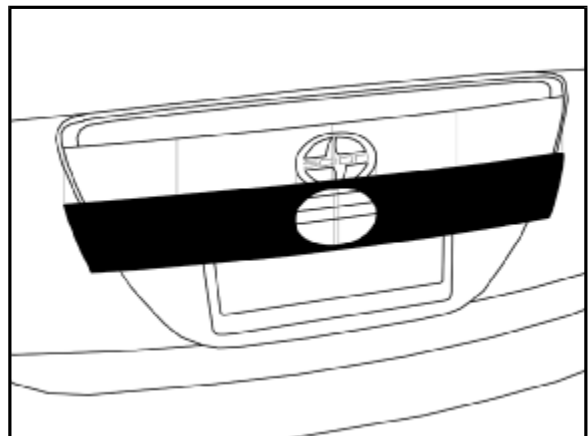

Fig. E1

- ⚠ A. Align cutouts around logo.
- ⚠ B. Align part uniformly to edge of factory components. Edge of appliqué should be flush to edge of factory component, ±1.0mm. (Fig. F1).
- C. Gently touch part into position.
- ⚠ 4. Verify alignment.
- ➡ 5. Press firmly into place. Roll fingertips in a back and forth motion to set adhesive. Be sure to roll thumb along outside and inside edges while applying pressure.

G. Install Front Logo Insert Trim (4 pieces)

- ➡ 1. Follow steps to warm components as required.
- 2. Remove adhesive liners from part. Be sure not to touch adhesive backing prior to installation.
- 3. Position and secure part.
 - ⚠ A. Align cutouts around logo.
 - ⚠ B. Align part uniformly to edge of factory components. Edge of appliqué should be flush to edge of factory component, ±1.0mm. (Fig. G1).
 - C. Gently touch part into position.
 - ⚠ 4. Verify alignment.
 - ➡ 5. Press firmly into place. Roll fingertips in a back and forth motion to set adhesive. Be sure to roll thumb along outside and inside edges while applying pressure.

H. Install Center Vent Trim

- ➡ 1. Follow steps to warm components as required.
- 2. Remove adhesive liners from part. Be sure not to touch adhesive backing prior to installation.
- 3. Position and secure part.
 - ⚠ A. Align cutouts around vent control wheels.
 - ⚠ B. Align part uniformly to edge of factory components. Edge of appliqué should be flush to edge of factory component, ±1.0mm. (Fig. H1).

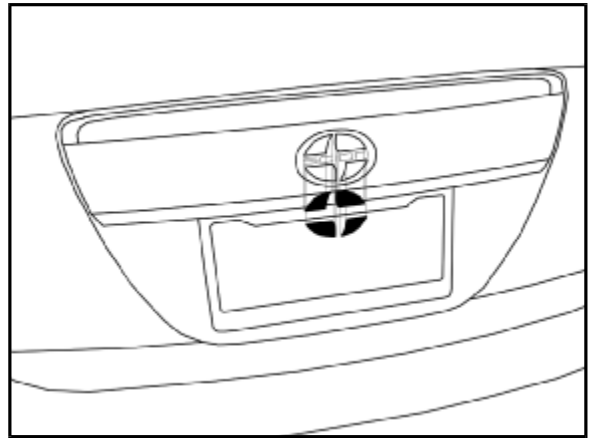

Fig. F1

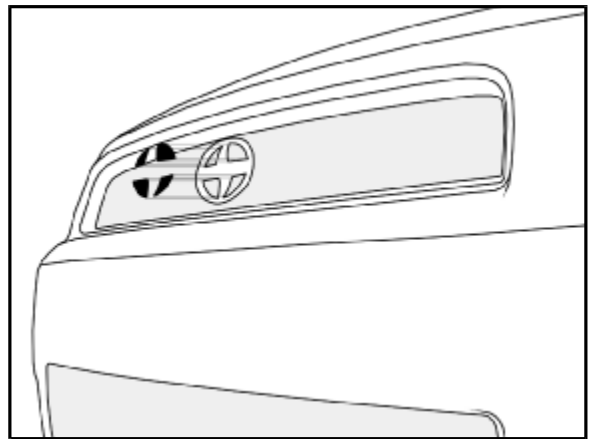

Fig. G1

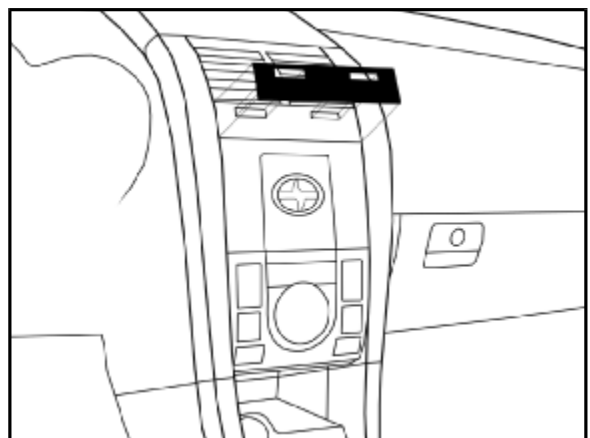





Fig. H1

C. Gently touch part into position.

 4. Verify alignment and function of vent control wheels.

 5. Press firmly into place. Roll fingertips in a back and forth motion to set adhesive. Be sure to roll thumb along outside and inside edges while applying pressure.

I. Install Radio Cover Surround Trim

 1. Follow steps to warm components as required.
2. Remove adhesive liners from part. Be sure not to touch adhesive backing prior to installation.

3. Position and secure part.

 A. Align part uniformly to edge of factory components. Edge of appliqué should be flush to edge of factory component, ±1.0mm. (Fig. I1).

B. Gently touch part into position.

 4. Verify alignment.

 5. Press firmly into place. Roll fingertips in a back and forth motion to set adhesive. Be sure to roll thumb along outside and inside edges while applying pressure.

J. Install Radio Cover Inner Trim

 1. Follow steps to warm components as required.
2. Remove adhesive liners from part. Be sure not to touch adhesive backing prior to installation.

3. Position and secure part.

 A. Align part uniformly to edge of factory components. Edge of appliqué should be flush to edge of factory component, ±1.0mm. (Fig. J1).

B. Gently touch part into position.

 4. Verify alignment.

 5. Press firmly into place. Roll fingertips in a back and forth motion to set adhesive. Be sure to roll thumb along outside and inside edges while applying pressure.

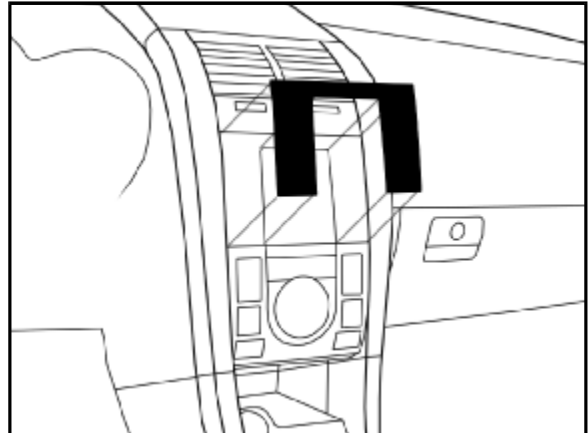

Fig. I1

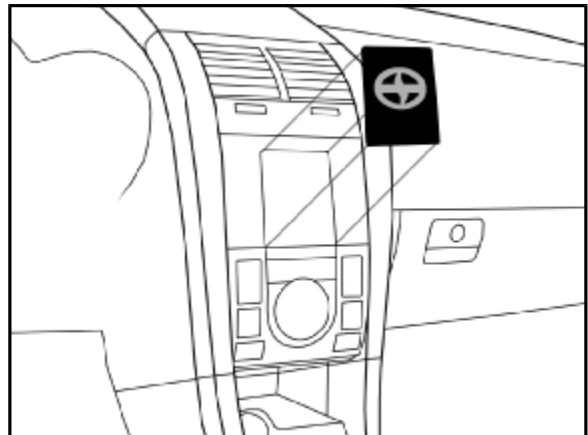

Fig. J1

K. Install Climate Surround Trim

- ➔ 1. Follow steps to warm components as required.
- 2. Remove adhesive liners from part. Be sure not to touch adhesive backing prior to installation.
- 3. Position and secure part.
 - ⚠ A. Align cutouts around buttons and dial.
 - ⚠ B. Align part uniformly to edge of factory components. Edge of appliqué should be flush to edge of factory component, ±1.0mm. (Fig. K1).
 - ⚠ C. Gently touch part into position.
- ⚠ 4. Verify alignment and function of buttons and dial.
- ➔ 5. Press firmly into place. Roll fingertips in a back and forth motion to set adhesive. Be sure to roll thumb along outside and inside edges while applying pressure.

L. Install Climate Surround Trim (2 pieces)

- ➔ 1. Follow steps to warm components as required.
- 2. Remove adhesive liners from part. Be sure not to touch adhesive backing prior to installation.
- 3. Position and secure part.
 - ⚠ A. Align part uniformly to edge of factory components. Edge of appliqué should be flush to edge of factory component, ±1.0mm. (Fig. L1).
 - ⚠ B. Gently touch part into position.
- ⚠ 4. Verify alignment.
- ➔ 5. Press firmly into place. Roll fingertips in a back and forth motion to set adhesive. Be sure to roll thumb along outside and inside edges while applying pressure.

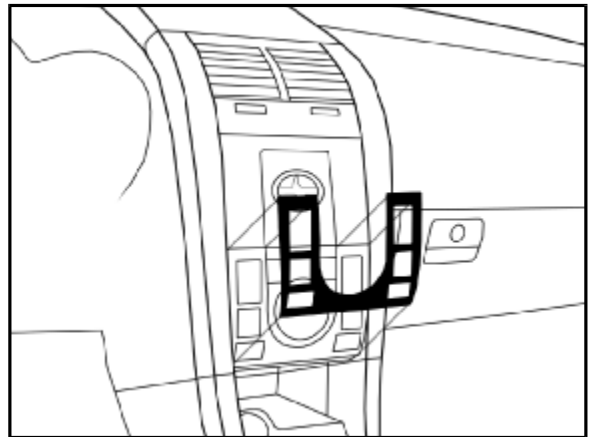

Fig. K1

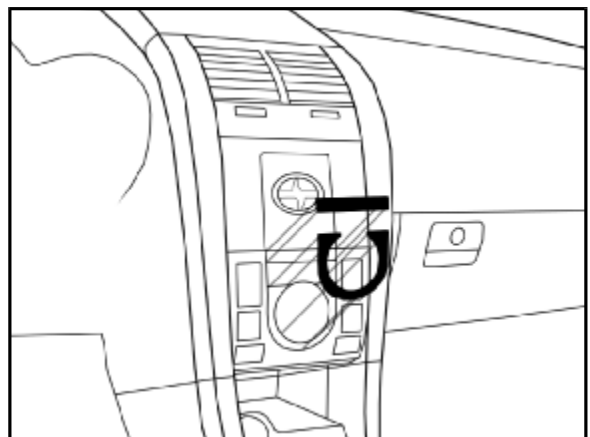

Fig. L1

M. Install Shift Surround Trim

- ➔ 1. Follow steps to warm components as required.
- 2. Remove adhesive liners from part. Be sure not to touch adhesive backing prior to installation.
- 3. Position and secure part.
 - ⚠ A. Align part uniformly to edge of factory components. Edge of appliqué should be flush to edge of factory component, ±1.0mm. (Fig. M1).
 - B. Gently touch part into position.
- ⚠ 4. Verify alignment.
- ➔ 5. Press firmly into place. Roll fingertips in a back and forth motion to set adhesive. Be sure to roll thumb along outside and inside edges while applying pressure.

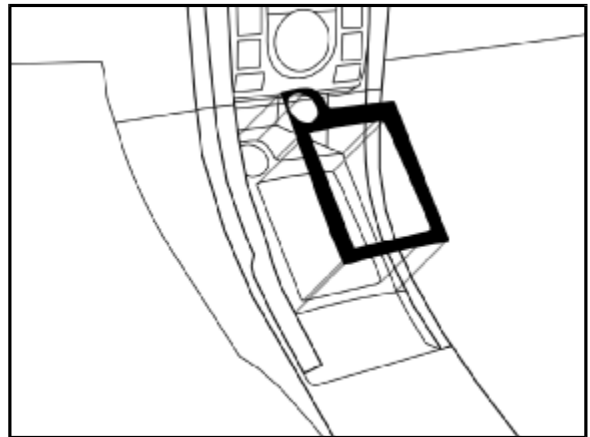

Fig. M1

N. Install Door Pull Inserts (Driver / Passenger)

- ➔ 1. Follow steps to warm components as required.
- 2. Remove adhesive liners from part. Be sure not to touch adhesive backing prior to installation.
- 3. Position and secure part.
 - ⚠ A. Align part uniformly to edge of factory components. Edge of appliqué should be flush to edge of factory component, ±1.0mm. (Fig. N1).
 - B. Gently touch part into position.
- ⚠ 4. Verify alignment.
- ➔ 5. Press firmly into place. Roll fingertips in a back and forth motion to set adhesive. Be sure to roll thumb along outside and inside edges while applying pressure.

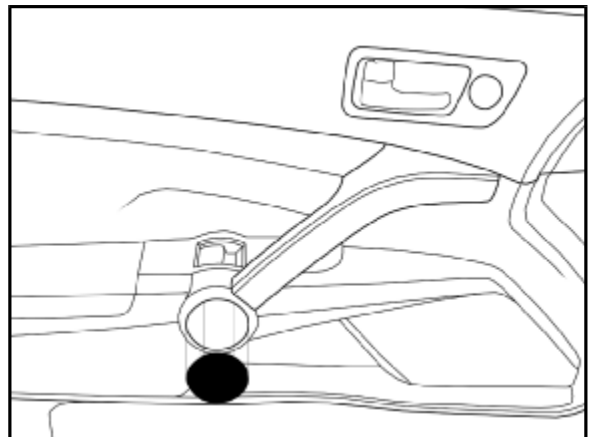

Fig. N1



Section III – Functional Verification

Check:

Look For:

- Vent Control Wheels
- Radio Cover Clearance
- Climate Control Buttons
- Climate Control Dial

Full movement, open and closed

Radio cover should open completely, no sticking.

All buttons should function properly, no sticking.

Full rotation.